

INSTRUCTIONS FOR USE

Lifeguard LG20 & LG50



WARNING

To avoid injury, always read this *Instructions for Use* and accompanied documents before using the product.



Operating instructions - Consult Instructions for use.

Design Policy and Copyright

® and ™ are trademarks belonging to the Arjo group of companies.

© Arjo 2023.

As our policy is one of continuous improvement, we reserve the right to modify designs without prior notice. The content of this publication may not be copied either whole or in part without the consent of Arjo.

Content

Warning and Cautions	4
Introduction.....	5
Intended Use	6
Operation.....	7
Accessories	14
Decontamination.....	16
Care and Preventive Maintenance	17
Warranty and Service	19
Dimensions and Data	20

Warning and Cautions

WARNING

Means: Safety warning. Failure to understand and obey this warning may result in injury to you or to others.

CAUTION

Means: Failure to follow these instructions may cause damage to all or parts of the system or equipment.

NOTE

Means: This is important information for the correct use of this system or equipment.

Serious incident

If a serious incident occurs in relation to this medical device, affecting the user, or the patient then the user or patient should report the serious incident to the medical device manufacturer or the distributor. In the European Union, the user should also report the serious incident to the Competent Authority in the member state where they are located.

General Warnings

WARNING

The age, size and condition of the patient should be assessed by a competent clinically qualified person before using the *Lifeguard* trolley, giving particular consideration to appropriate use of the safety sides.

WARNING

If any part is missing or damaged - do NOT use the product.

WARNING

Do not use accessories that are not designed or approved for use with the *Lifeguard* trolley.

WARNING

Always apply the brakes when the *Lifeguard* trolley is stationary.

WARNING

Raise the safety sides before moving the *Lifeguard* trolley with a patient.

WARNING

Children and restless or disorientated patients should not be left unattended at any time.

WARNING

Before turning (rolling) a patient on the *Lifeguard* trolley or performing a lateral transfer, adjust the mattress platform to a comfortable working height; be aware that the *Lifeguard* trolley may overbalance if the patient's weight is not evenly distributed across the mattress platform.

Introduction

Fig. 1



This manual gives instructions for the use and maintenance of the *Lifeguard*® patient trolleys, model numbers LG20 (See **Fig. 1**) and LG50 (See **Fig. 2**).

All *Lifeguard* trolley models have a radio translucent mattress platform. A full-length X-ray cassette tray can be supplied as an option.

Fig. 2



Intended Use

The Lifeguard trolley range is intended for use in hospitals to provide a mattress support surface and to transport patients. The Lifeguard trolleys may be used for general and emergency admissions, examination, diagnostic X-ray and initial treatment. They are also appropriate for patient transfer between departments, wards and theatre.

Lifeguard trolleys must be used by appropriately trained caregivers with adequate knowledge of the care environment, its common practices and procedures, and in accordance with the guidelines in the Instruction for Use.

The trolleys should only be used for the purpose specified in this Instructions for Use. Any other use is prohibited.

Patient/Resident assessment

We recommend that facilities establish regular assessment routines. Caregivers should assess each resident/patient according to the following criteria prior to use:

- To ensure the patient can use the trolley safely, their age, size and condition should be assessed by a clinically qualified person.

- The maximum safe working load is:

Lifeguard 20: 180 kg (392 lbs.) (See Fig. 3)

Lifeguard 50: 250 kg (550 lbs.) (See Fig. 4)

If the patient/resident does not meet these criteria an alternative equipment/system shall be used.

Fig. 3

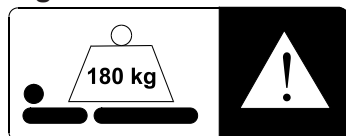
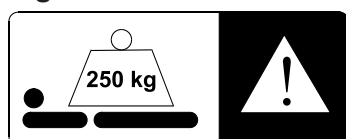

Fig. 4



Expected service life

The lifetime of this product is typically ten (10) years. "Lifetime" is defined as the period during which the product will maintain the specified performance and safety, provided it has been maintained and operated in conditions of normal use in accordance with the requirements in the Instructions for Use.

Operation

Safety

For the safety of operator, patient and equipment:

- Always use a mattress of the correct size and type for the *Lifeguard* trolley.
- Do not expose the equipment, especially the mattress, to naked flames, cigarettes etc.
- Before operating the *Lifeguard* trolley, make sure that the patient is positioned correctly to avoid entrapment and imbalance.
- When the *Lifeguard* trolley is operated, check that no obstacles are in its path.
- Keep these instructions handy for reference.

Mattress

The mattress is secured to the platform by means of hook and loop tapes on the mattress underside and the laminate top.

Push Bar Handles

Adjust the height of the handles

(2 Steps) (See Fig. 5)

1. Press the spring-loaded release button (A) and raise or lower the handle as required (B).
2. Let go of the button to lock the handle in the high or low position.

Fig. 5

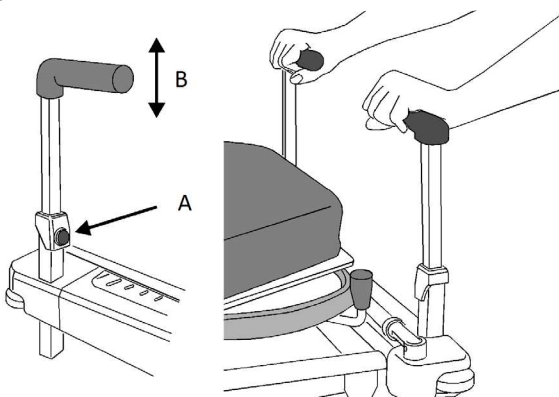

Fig. 6

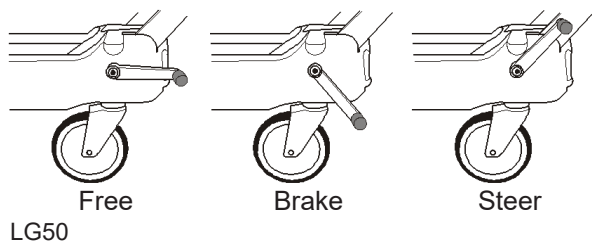
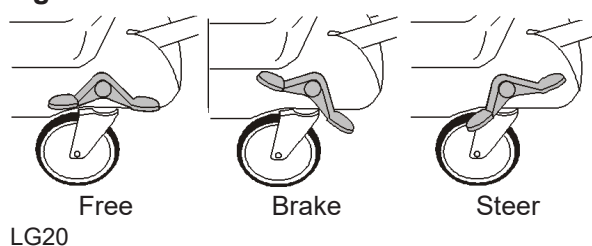

Fig. 7



Breaks and Steering

(See Fig. 6) (See Fig. 7)

Linked brake pedals are situated at the head end of the *Lifeguard* trolley; model LG50 has additional pedals at the foot end.

- When the pedals are horizontal, the castors are free to rotate and swivel.
- When the pedals are in the BRAKE position, the brakes are applied on all four castors.
- When the pedals are in the STEER position, one foot end castor is prevented from swivelling and the *Lifeguard* trolley can be pushed from the head end.

Easytrack® 5th Wheel Steering System (Optional)

When the pedals are in the STEER position, the central 5th wheel is prevented from swivelling; the *Lifeguard* trolley will keep on a straight course in any direction and can be steered by pivoting about the 5th wheel.

Height and Tilt Adjustment Model LG50

The height and the tilt angle of the mattress platform are adjusted using a group of five foot pedals on either side of the *Lifeguard* trolley. The three pedals marked with a black ▲ in the bottom row are used to raise the platform. The two pedals marked with a red ▼ in the top row are used to lower the platform. (See Fig. 8)

Fig. 8



Tilt Adjustment (See Fig. 8)

Raise one end of the platform

- Operate the “raise” pedal (black ▲) nearest that end of the *Lifeguard* trolley with a pumping action.

Lower one end of the platform

- Press down on the “lower” pedal (red ▼) nearest that end of the *Lifeguard* trolley and keep it pressed.

NOTE

There is an additional “lower” pedal (red ▼) that enables head down tilt to be applied from the head end of the *Lifeguard* trolley.

Height Variation

Raise the platform

- Operate the central “raise” pedal (black ▲) with a pumping action.

Lower the platform

- Press down both “lower” pedals (red ▼) and keep them pressed.

If the platform is raised or lowered when tilted, the tilt angle will be maintained until the leading end reaches the limit of travel, when the platform will return to the horizontal condition.

Fig. 9

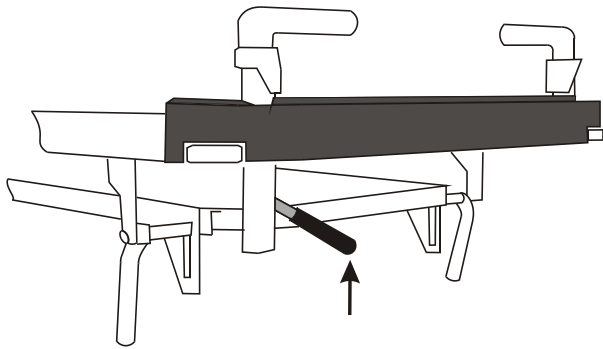

Height and Tilt Adjustment Model LG20

Tilt Adjustment (See Fig. 9)

The angle of head down tilt is adjustable by raising the lever located just underneath the head end of the mattress platform.

(3 Steps)

1. Take the weight of the mattress platform and raise the lever.
2. Lift or lower the mattress platform to adjust the amount of tilt.
3. Release the lever when the required angle has been reached.

Fig. 10

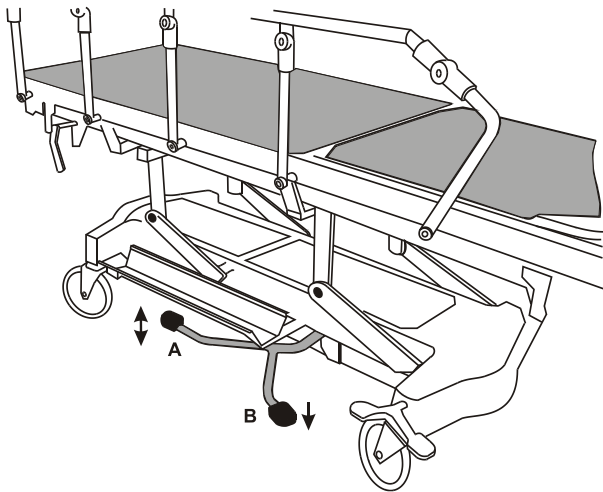

Height Variation (See Fig. 10)

The height of the mattress platform can be adjusted from either side of the *Lifeguard* trolley by using the two foot pedals (A) and (B).

Raise the platform

- Operate the foot pedal (A) with a pumping action.

Lower the platform (2 Steps)

1. Raise pedal (A) or press pedal (B) down and keep it pressed.
2. Release the pedal when the platform is at the desired height or has reached the lowest position.

Fig. 11

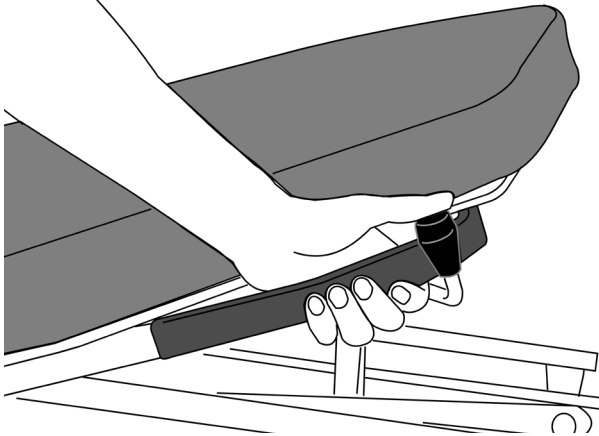

Backrest

NOTE

The amount of effort needed to raise or lower the backrest will vary depending on patient weight and mobility. With a very heavy patient, the backrest may fall quickly if it is not supported when released.

Adjust the backrest

(2 Steps) (See Fig. 11)

1. Grasp the handle firmly, press the release knob and lift the backrest assisted by the gas spring or push it down against the action of the gas spring.
2. Let go of the release knob to lock the backrest at any angle.

Fig. 12

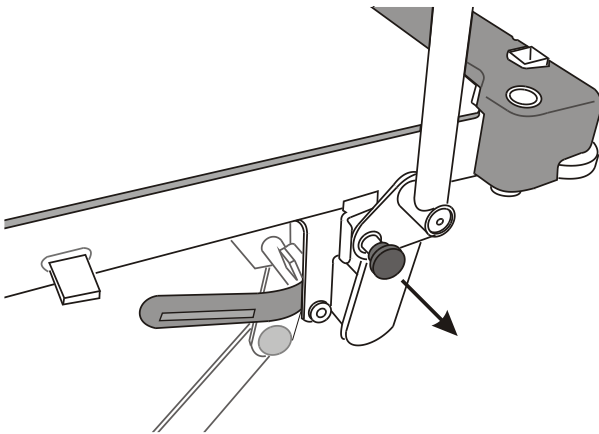

Safety Sides

(See Fig. 12)

Raise the safety side

- Hold the top rail and lift until it locks into position at maximum height.

Lower the safety side

- Hold the top rail with one hand, pull the release button at the foot end and lower the rail toward the head.

CAUTION

Do not use the safety sides to move the trolley. Only use the push bar handles to operate the trolley.

Fig. 13

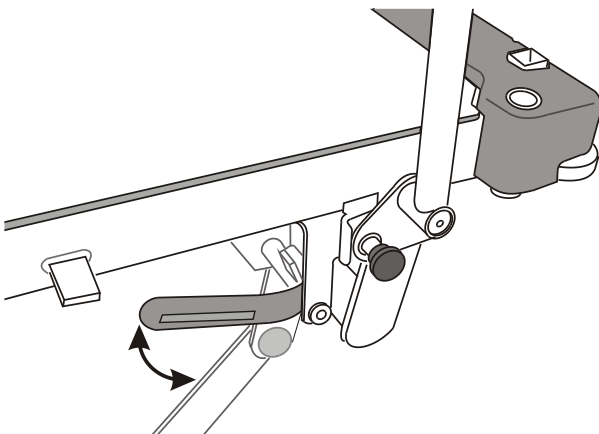

X-Ray Photography (Optional)

The mattress and platform are radio translucent. A full-length cassette tray can be included as a factory-fitted option, which can be accessed from either side of the *Lifeguard* trolley.

Load or unload cassettes

(2 Steps) (See Fig. 13)

1. Lower the tray by turning the handles at both ends of the *Lifeguard* trolley to the vertical position.
2. Load or unload the cassette and raise the tray again by turning the handles to the horizontal position.

Fig. 14

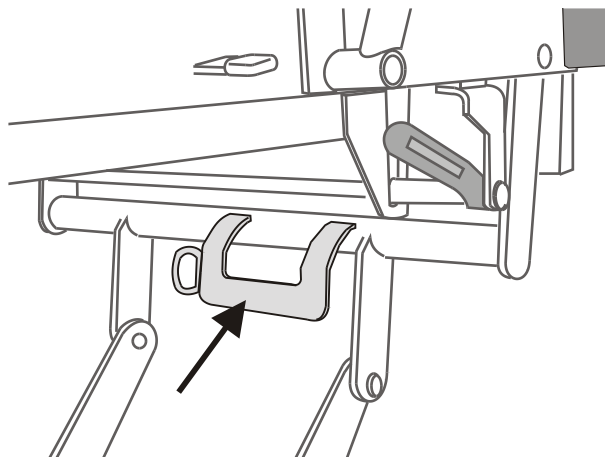

Fig. 15

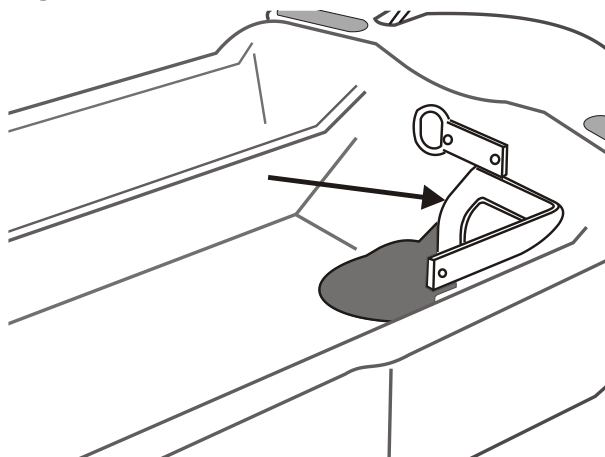

Fig. 16

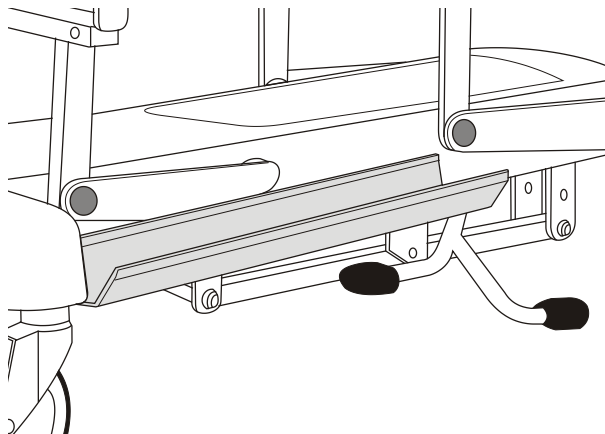
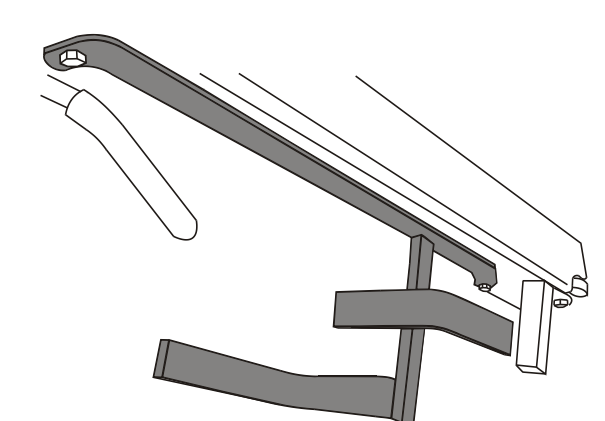

Fig. 17



Oxygen Therapy Equipment

WARNING

Ensure that the oxygen line does not become entangled or trapped which could cause damage to the line or loss of supply.

Ensure that when the *Lifeguard* trolley is operated it does not collide with the installed equipment, especially at low height.

Model LG50

A recess in the base of the *Lifeguard* trolley will accommodate a size D, E or F oxygen cylinder. The stainless steel liner can be lifted out for cleaning.

In addition, facilities are provided for the installation and use of oxygen therapy systems. A short rail (Medirail) is provided at the head end of the *Lifeguard* trolley to accommodate the flow meter and injection suction unit. (See Fig. 14)

A universal mounting bracket is installed in the base of the *Lifeguard* trolley to accept the suction receiver jar. (See Fig. 15) If the mounting bracket is not already fitted, remove the plastic cover from the hole in the base cover moulding and attach the bracket with two 6 mm Button Head screws and nuts using the pre-drilled holes in the base frame.

Model LG20

The oxygen cylinder holder is mounted on the base of the *Lifeguard* trolley. It will accommodate a size D, E or F oxygen cylinder. (See Fig. 16)

NOTE

There is an optional Medirail that can be attached to the head end of the mattress platform on *Lifeguard* trolley model LG20. (See Fig. 17)

Fig. 18



IV Drip Rod MB-ACC32

Install the IV pole in one of the four tubular sockets at the corners of the platform (A). (See Fig. 18)

WARNING

The maximum total load on the hooks must not exceed 5 kg.

The maximum load attached to the lower tube must not exceed 10 kg.

Fig. 19

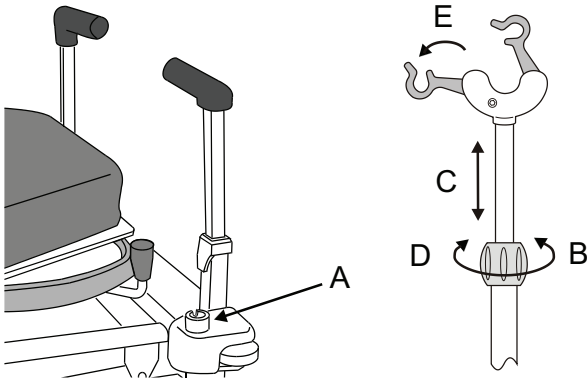

Adjust the height

(5 Steps) (See Fig. 19)

1. Hold the telescoping IV pole firmly.
2. Loosen the locking collar (B).
3. Lift or lower the inner IV pole as required (C).
4. Re-tighten the locking collar firmly (D).
5. Fold out the hooks (E).

NOTE

Be careful not to lift the IV pole out of the socket when raising the hook.

Fig. 20

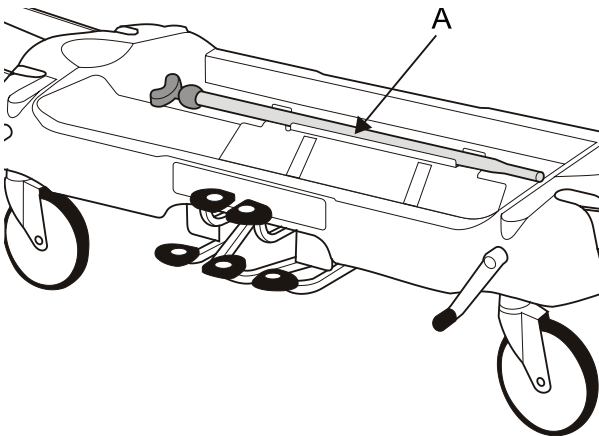

Storage

Adjust the IV pole to minimum length and tighten the locking collar.

The IV pole (A) is stored in a recess on the base of the Lifeguard trolley (See Fig. 20) or in a tube underneath the mattress platform (See Fig. 21).

Model LG50

Fig. 21

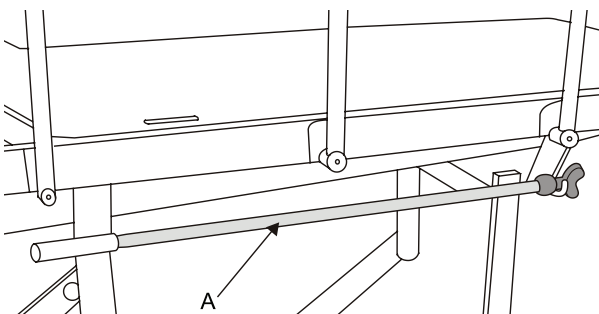

Model LG20

Fig. 22

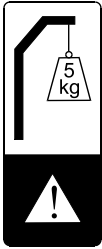

IV Drip Rod 799.501

The built-in IV pole is located at the head end of the *Lifeguard* trolley.

WARNING

Do not exceed the maximum safe load of 5 kg.

Fig. 23

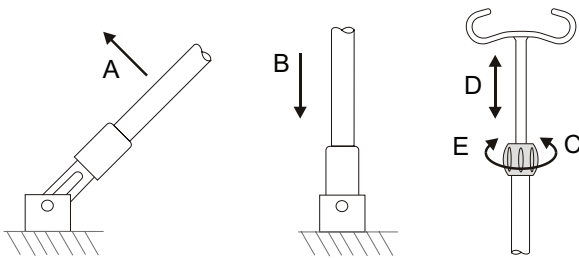

Lift the IV pole to the vertical position (A) and allow it to drop into the tubular socket on the platform (B). (See Fig. 23)

Adjust the height

(4 Steps) (See Fig. 23)

1. Hold the telescoping IV pole firmly.
2. Loosen the locking collar (C).
3. Lift or lower the hook as required (D).
4. Re-tighten the locking collar firmly (E).

NOTE

Be careful not to lift the IV pole out of the socket when raising the hook.

Storage

Adjust the IV pole to minimum height and tighten the locking collar, then lift the IV pole out of the socket and fold it down.

Accessories

A range of accessories, including mattresses, is available from Arjo. Details are available on request.

Accessories currently available for *Lifeguard* LG20 and LG50 are shown in the table below.

ACCESSORY NAME	PRODUCT CODE
Foot end panel & bow	157009
Foot panel with monitor table	157018
Clip-on table	157021
Arm rest	157006PE02
Safety side pads (grey)	99901PE16
DIN rail kit (head end)	LG/ACC03
Oxygen bottle holder (PD size)	LG/ACC04
DIN rail kit (foot end)	LG/ACC05
Mattress with two-way stretch cover - 65 mm thick	LGMAT/10
Mattress with two-way stretch cover - 80 mm thick	LGMAT/12
Two part transfer mattress	LGMAT/13
Two part transfer mattress "Pennyla"	LGMAT/13PN
Bi-Flex pressure reducing mattress	TRM2
Bi-Flex pressure redistribution mattress	TRM3

Some accessories may not be available in all markets. Arjo reserves the right to alter specifications and availability without notification.

The following section describes some commonly used accessories. Other accessories are supplied with instructions for use.

LGMAT/10

The LGMAT/10 is a one piece mattress with two-way stretch anti-static PU cover, used to provide the patient with adequate comfort during transport and to facilitate cleaning and disinfection.

LGMAT/12

The LGMAT/12 is a one piece, twin-foam mattress with two-way stretch anti-static PU cover, used to provide the patient with increased comfort during transport and to facilitate cleaning and disinfection.

LGMAT/13

The LGMAT/13 transfer mattress is designed to allow patients to be moved easily and with minimal discomfort from a *Lifeguard* trolley to an adjacent surface.

Foot Panel with Monitor Table 157018

Install the foot panel in the square sockets at the end of the mattress platform, with the clipboard on the outside.

Fig. 24



WARNING

Maximum safe working load 12 kg evenly distributed.

Fig. 25

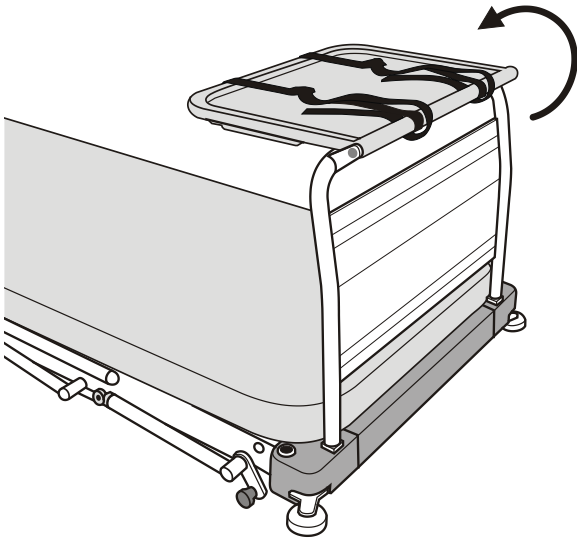

Use the monitor table

(2 Steps) (See Fig. 25)

1. Place the clipboard in a horizontal position.
2. Use the straps to secure the monitor to the table.

Remove the foot panel

- Lift it out of the sockets.

Decontamination

The following processes are recommended, but should be adapted to comply with the local or national guidelines (Decontamination of Medical Devices) which may apply within the Healthcare Facility or the country of use. If you are uncertain, you should seek advice from your local Infection Control Specialist.

The *Lifeguard* system should be routinely decontaminated between patients and at regular intervals while in use; as is good practice for all reusable medical devices.

WARNING

Protective clothing should always be worn when carrying out decontamination procedures.

CAUTION

Do not use Phenol-based solutions or abrasive compounds or pads during the decontamination process as these will damage the surface coating. Do not boil or autoclave the cover.

Clean

(2 Steps)

1. Clean all exposed surfaces and remove any organic debris by wiping with a cloth moistened with a simple (neutral) detergent and water.
2. Dry thoroughly.

Chemical disinfection

(4 Steps)

To protect the integrity of the cover we recommend a chlorine-releasing agent, such as sodium hypochlorite, at a strength of 1,000ppm available chlorine (this may vary from 250ppm to 10,000ppm depending on local policy and contamination status).

1. Wipe all cleaned surfaces with the solution, rinse and dry thoroughly.
2. Alcohol based disinfectants (maximum strength 70%) may be used as an alternative.
3. Ensure the product is dry before storage.
4. If an alternative disinfectant is available and selected from the wide variety, we recommend that suitability for use is confirmed with the chemical supplier prior to use.

Clean the mattress

(2 Steps)

1. Wipe all surfaces with a disposable cloth soaked in a neutral detergent and hand hot water.
2. Rinse with clean water and dry with disposable paper towels.

Disinfect the mattress

- Wipe all surfaces with a solution of sodium dichloroisocyanurate (NaDCC) at a concentration of 1,000ppm (0.1%) available chlorine.

Care and Preventive Maintenance

This product is subject to wear and tear during use. To ensure that it continues to perform within its original specification, preventive maintenance procedures should be carried out at the intervals shown.

WARNING

This list indicates the minimum level of preventive maintenance recommended by the manufacturer. More frequent inspections should be carried out when the product is subjected to heavy use or aggressive environments, or where required by local regulations. Failure to carry out these checks, or continuing to use the product if a fault is found, may compromise the safety of both the patient and carer/user. Preventive maintenance can help to prevent accidents.

Actions to be done by carer/user	Daily	Weekly	Yearly
Clean and disinfect as shown in <i>“Decontamination” on page 16.</i>	X		
Check operation of safety sides		X	
Visually check castors		X	
Inspect the mattress as described on the next page	X		
Check safety side pads (if fitted)		X	

If the result of any of these tests is unsatisfactory, contact Arjo or an approved service agent.

WARNING

The procedures below must be carried out by suitably trained and qualified personnel. Failure to do so may result in injury or an unsafe product.

Actions to be done by carer/user	Daily	Weekly	Yearly
Check the operation of the lifting mechanism as described below			X
Check the operation of the backrest raise and lower			X
Check operation of castors, paying special attention to braking and steering functions			X
Check the hydraulic pump for leaks			X
Check all nuts, bolts and other fasteners are present and correctly tightened			X
Check all accessories, paying particular attention to fasteners and moving parts			X

Mattress

Check the cover, especially around the seams, for cuts or splits that may allow fluid ingress. Replace the cover if necessary.

Unzip the cover and inspect the mattress core for signs of fluid ingress, e.g. staining or dampness. Replace the complete mattress if necessary.

Lifting Mechanism

Check the operation. A steady firm resistance should be felt over the full stroke of the “raise” pedals. If the pedal pressure is variable or yielding, this may indicate the presence of air in the system and can be remedied as follows:

(3 Steps)

1. Raise the platform to full height. Continue pumping for four or five pedal strokes then lower the platform fully.
2. Repeat this action two or three times.
3. If firm and steady pedal operation is not restored, contact Arjo or an approved service agent.



Warranty and Service

Arjo standard terms and conditions apply to all sales. A copy is available on request. These contain full details of warranty terms and do not limit the statutory rights of the consumer.

For service, maintenance and any questions regarding this product, please contact your local Arjo office or authorised distributor. A list of Arjo offices can be found at the back of this manual.

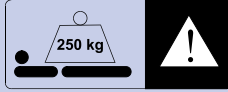
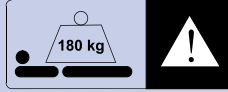
Dimensions and Data

	Model LG50	Model LG20
Overall length	211 cm	211 cm
Overall width	77 cm	77 cm
Height of mattress platform (max.)	93 cm	92 cm
Height of mattress platform (min.)	56 cm	60 cm
Tilt (max.) head down	12°	12°
Tilt (max.) foot down	12°	N/A
Backrest adjustment	0 to 87°	0 to 87°
Castors (diameter)	20 cm	20 cm
Product weight (approximate)	138 kg	120 kg
Product weight with X-ray cassette tray	145 kg	127 kg
Safe working load	250 kg 	180 kg 
Mattress size	195 x 67 x 6.5 cm 195 x 67 x 7.5 cm 195 x 67 x 8 cm 195 x 67 x 13 cm	195 x 67 x 6.5 cm 195 x 67 x 7.5 cm 195 x 67 x 8 cm 195 x 67 x 13 cm

	Indicates the product is a Medical Device according to EU Medical Device Regulation 2017/745
	CE marking indicating conformity with European Community harmonised legislation
	Unique device identifier

Transport and Storage

Handle with care. Do not drop. Avoid shock or violent impact.

Operating conditions:

- Temperature: -10°C to +40°C
- Relative humidity: 20% to 90% at 30°C, non-condensing
- Atmospheric pressure: 700hPa to 1060hPa

This equipment should be stored in a clean, dry and well-ventilated area which meets the following conditions:

- Temperature: -10°C to +50°C
- Relative humidity: 20% to 90% at 30°C, non-condensing
- Atmospheric pressure: 700hPa to 1060hPa

End of Life Disposal

Equipment should be disassembled and recycled in accordance with local or national regulation.

Components that are primarily made up of different kinds of metal (containing more than 90% metal by weight) for example bed frame, should be recycled as metals.

UK Symbol explanation	
This section is only applicable to United Kingdom (UK) market when UK marking is applied to the Arjo medical device labelling.	
	UK marking indicating conformity with UK Medical Devices Regulations 2002 (SI 2002 No 618, as amended)
<p>UK Responsible Person & UK Importer:</p> <p>Arjo (UK) Ltd, ArjoHuntleigh House, Houghton Regis. LU5 5XF</p> <p>Is the appointed UK Responsible Person as defined in UK Medical Devices Regulations 2002 (SI 2002 No 618, as amended).</p> <p>For Northern Ireland (NI) CE marking will still apply until further amendment to applicable regulations.</p>	

Intentionally left blank

AUSTRALIA
Arjo Australia
Building B, Level 3
11 Talavera Road
Macquarie Park, NSW, 2113,
Australia
Phone: 1800 072 040

BELGIQUE / BELGIË
Arjo Belgium
Evenbroekveld 16
9420 Erpe-Mere
Phone: +32 (0) 53 60 73 80
Fax: +32 (0) 53 60 73 81
E-mail: info.belgium@arjo.com

BRASIL
Arjo Brasil Equipamentos Médicos Ltda
Rua Marina Ciufuli Zanfelice, 329 PB02
Galpão - Lapa
São Paulo - SP - Brasil
CEP: 05040-000
Phone: 55-11-3588-5088
E-mail: vendas.latam@arjo.com
E-mail: servicios.latam@arjo.com

CANADA
Arjo Canada Inc.
90 Matheson Boulevard West
Suite 350
CA-MISSISSAUGA, ON, L5R 3R3
Tel/Tél: +1 (905) 238-7880
Free: +1 (800) 665-4831
Fax: +1 (905) 238-7881
E-mail: info.canada@arjo.com

ČESKÁ REPUBLIKA
Arjo Czech Republic s.r.o.
Na Strži 1702/65
140 00 Praha
Czech Republic
Phone No: +420225092307
E-mail: info.cz@arjo.com

DANMARK
Arjo A/S
Vassingerødvej 52
DK-3540 LYNGE
Tel: +45 49 13 84 86
Fax: +45 49 13 84 87
E-mail: dk_kundeservice@arjo.com

DEUTSCHLAND
Arjo GmbH
Peter-Sander-Strasse 10
DE-55252 MAINZ-KASTEL
Tel: +49 (0) 6134 186 0
Fax: +49 (0) 6134 186 160
E-mail: info-de@arjo.com

ESPAÑA
ARJO IBERIA S.L.
Poligono Can Salvatella
c/ Cabanyes 1-7
08210 Barberà del Valles
Barcelona - Spain
Telefono 1: +34 900 921 850
Telefono 2: +34 931 315 999

FRANCE
Arjo SAS
2 Avenue Alcide de Gasperi
CS 70133
FR-59436 RONCQ CEDEX
Tél: +33 (0) 3 20 28 13 13
Fax: +33 (0) 3 20 28 13 14
E-mail: info.france@arjo.com

HONG KONG
Arjo Hong Kong Limited
Room 411-414, 4/F, Manhattan Centre,
8 Kwai Cheong Road, Kwai Chung, N.T.,
HONG KONG
Tel: +852 2960 7600
Fax: +852 2960 1711

ITALIA
Arjo Italia S.p.A.
Via Giacomo Peroni 400-402
IT-00131 ROMA
Tel: +39 (0) 6 87426211
Fax: +39 (0) 6 87426222
E-mail: Italy.promo@arjo.com

MIDDLE EAST
Arjo Middle East FZ-LLC
Office 908, 9th Floor,
HQ Building, North Tower,
Dubai Science Park,
Al Barsha South
P.O. Box 11488, Dubai,
United Arab Emirates
Direct +971 487 48053
Fax +971 487 48072
Email: Info.ME@arjo.com

NEDERLAND
Arjo Nederland BV
Biezenwei 21
4004 MB TIEL
Postbus 6116
4000 HC TIEL
Tel: +31 (0) 344 64 08 00
Fax: +31 (0) 344 64 08 85
E-mail: info.nl@arjo.com

NEW ZEALAND
Arjo Ltd
34 Vestey Drive
Mount Wellington
NZ-AUCKLAND 1060
Tel: +64 (0) 9 573 5344
Free Call: 0800 000 151
Fax: +64 (0) 9 573 5384
E-mail: nz.info@Arjo.com

NORGE
Arjo Norway AS
Olaf Helsets vei 5
N-0694 OSLO
Tel: +47 22 08 00 50
Faks: +47 22 08 00 51
E-mail: no.kundeservice@arjo.com

ÖSTERREICH
Arjo Austria GmbH
Lemböckgasse 49 / Stiege A / 4.OG
A-1230 Wien
Tel: +43 1 8 66 56
Fax: +43 1 866 56 7000

POLSKA
Arjo Polska Sp. z o.o.
ul. Ks Piotra Wawrzyniaka 2
PL-62-052 KOMORNIKI (Poznań)
Tel: +48 691 119 999
E-mail: arjo@arjo.com

PORTUGAL
Arjo em Portugal
MAQUET Portugal, Lda.
(Distribudor Exclusivo)
Rua Poeta Bocage n.º 2 - 2G
PT-1600-233 Lisboa
Tel: +351 214 189 815
Fax: +351 214 177 413
E-mail: Portugal@arjo.com

SUISSE / SCHWEIZ
Arjo Switzerland AG
Fabrikstrasse 8
Postfach
CH-4614 HÄGENDORF
Tél/Tel: +41 (0) 61 337 97 77
Fax: +41 (0) 61 311 97 42

SUOMI
Arjo Scandinavia AB
Riihitontuntie 7 C
02200 Espoo
Finland
Puh: +358 9 6824 1260
E-mail: Asiakaspalvelu.finland@arjo.com

SVERIGE
Arjo International HQ
Hans Michsensgatan 10
SE-211 20 MALMÖ
Tel: +46 (0) 10 494 7760
Fax: +46 (0) 10 494 7761
E-mail: kundservice@arjo.com

UNITED KINGDOM
Arjo UK and Ireland
Houghton Hall Park
Houghton Regis
UK-DUNSTABLE LU5 5XF
Tel: +44 (0) 1582 745 700
Fax: +44 (0) 1582 745 745
E-mail: sales.admin@arjo.com

USA
Arjo Inc.
2349 W Lake Street Suite 250
US-Addison, IL 60101
Tel: +1 (630) 307-2756
Free: +1 (800) 323-1245
Fax: +1 (630) 307 6195
E-mail: us.info@arjo.com

JAPAN
Arjo Japan K.K.
東京都港区虎ノ門三丁目7番8号
ランディック第2虎ノ門ビル9階
Tel: +81 (0)3-6435-6401
Fax: +81 (0)3-6435-6402
E-mail: info.japan@arjo.com

At Arjo, we believe that empowering movement within healthcare environments is essential to quality care. Our products and solutions are designed to promote a safe and dignified experience through patient handling, medical beds, personal hygiene, disinfection, diagnostics, and the prevention of pressure injuries and venous thromboembolism. With over 6500 people worldwide and 65 years caring for patients and healthcare professionals, we are committed to driving healthier outcomes for people facing mobility challenges.



ArjoHuntleigh AB
Hans Michelsensgatan 10
211 20 Malmö, Sweden
www.arjo.com

arjo

