

Belmont
Instrument Corporation

The New Standard of Care

The Belmont® **Rapid Infuser**
Because Your Patient's Life May Depend On It!



**COMBAT TESTED
HOSPITAL APPROVED**

The Belmont® **Rapid Infuser**

**For safe, high-volume infusion
of blood or blood products...
in surgery...in trauma**

The Belmont® Rapid Infuser combines advanced microprocessor technology with an efficient mechanical system to give patients the vital warm fluids they need when they need them.

It infuses large amounts of life-sustaining fluids warmed to physiological temperature at rates from **10 - 1000 ml/min.**



Unparalleled Safety, Efficiency and Usability

- **Automatic Air Removal**
- **Precise Control of Infusion Rate**
- **Efficient Dry Heat**
- **Simple set up**
- **Small and lightweight**
- **Automatic Alarms Avoid Unsafe Conditions**
- **On Screen Instructions**
- **Automatic Line Pressure Monitoring**
- **Optional Large Reservoir Facilitates Consistent Fluid Mixtures**
- **Operator Controlled Bolus Infusion**

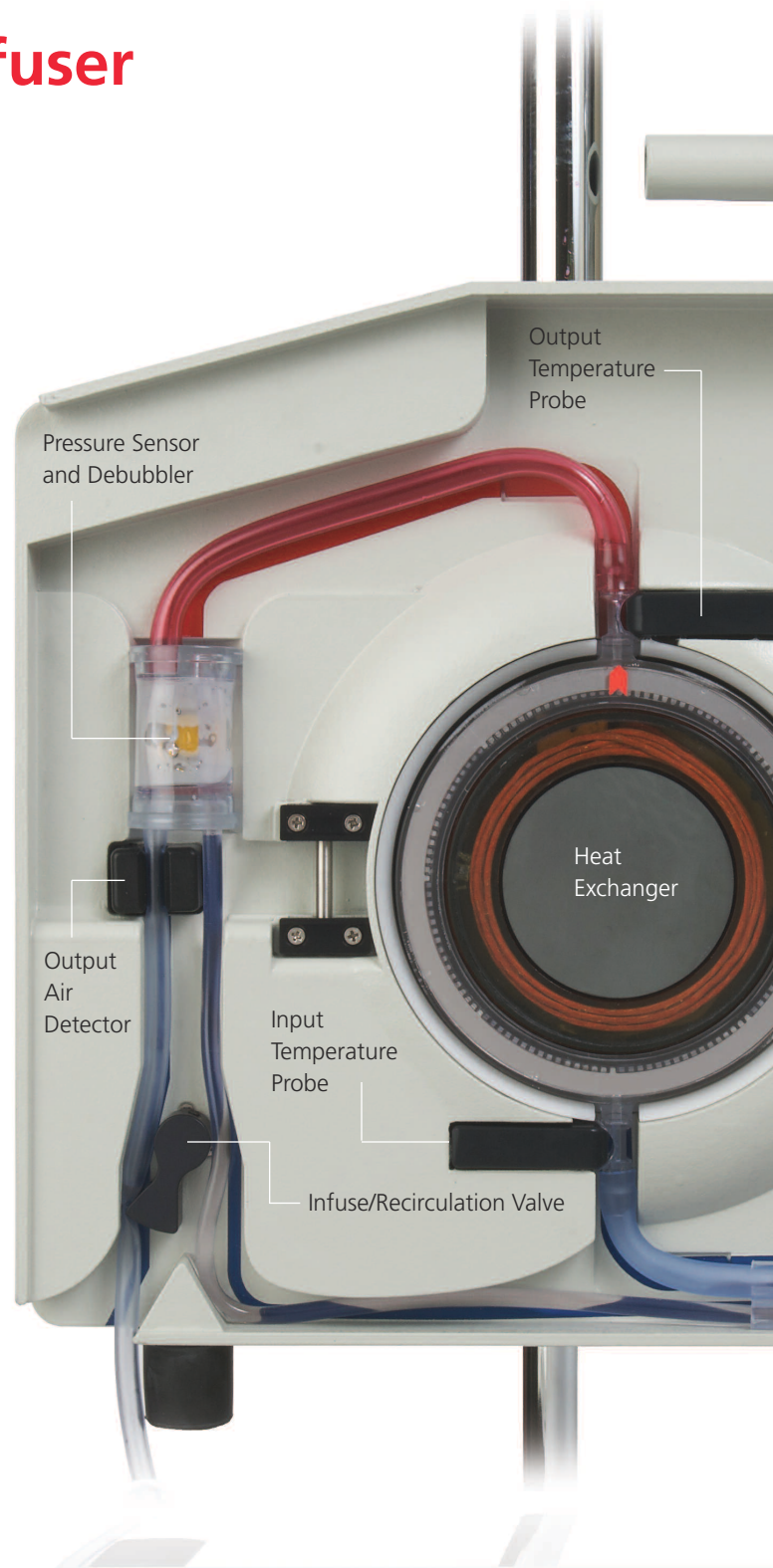

www.belmontinstrument.com

Call 866-663-0212 or email sales@belmontinstrument.com for more information or to schedule a demonstration.

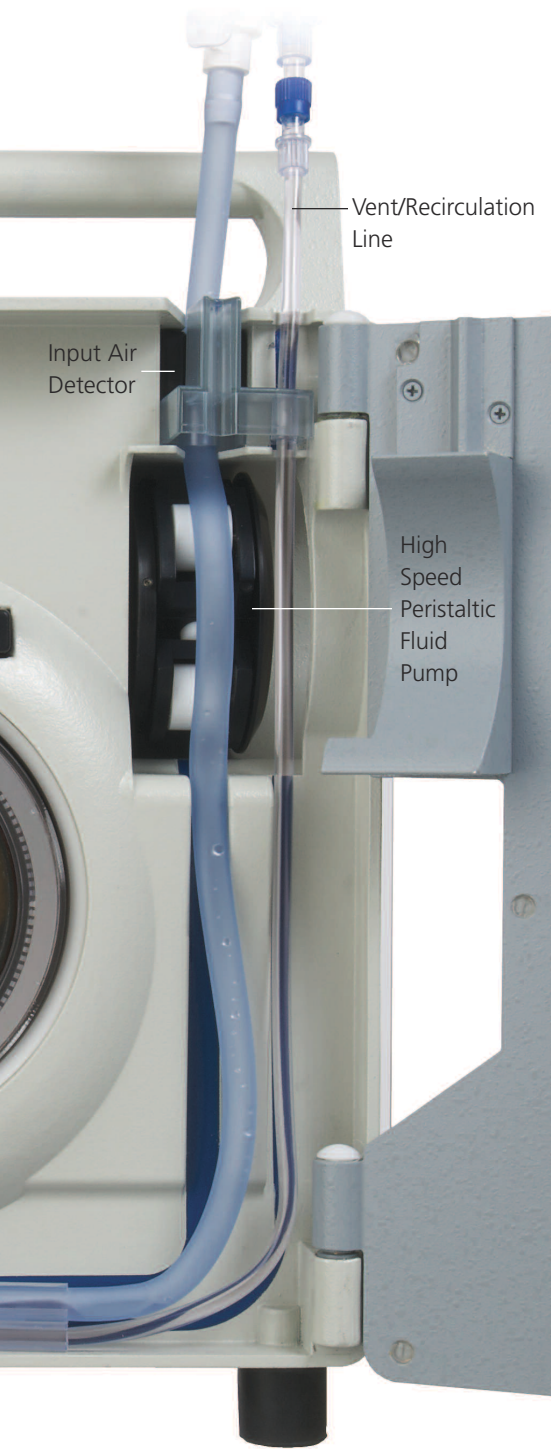

→ Main Features

Unique Instant Heater

- Fluid, blood, or blood products warmed to normothermia in a single pass
- No overheating or “hot spots”
- Patented induction heater warms without water baths or microwaves

High Speed Peristaltic Fluid Pump

- Complete flow control from 2.5 - 1,000 ml/min at the touch of a button
- Eliminates dangerous, uncontrollable bag compressors
- Monitors total infused volume for accurate I/O charting
- Optional 3 liter reservoir eliminates frequent bag changing

→ Flow and Temperature Delivered Rapidly and Accurately

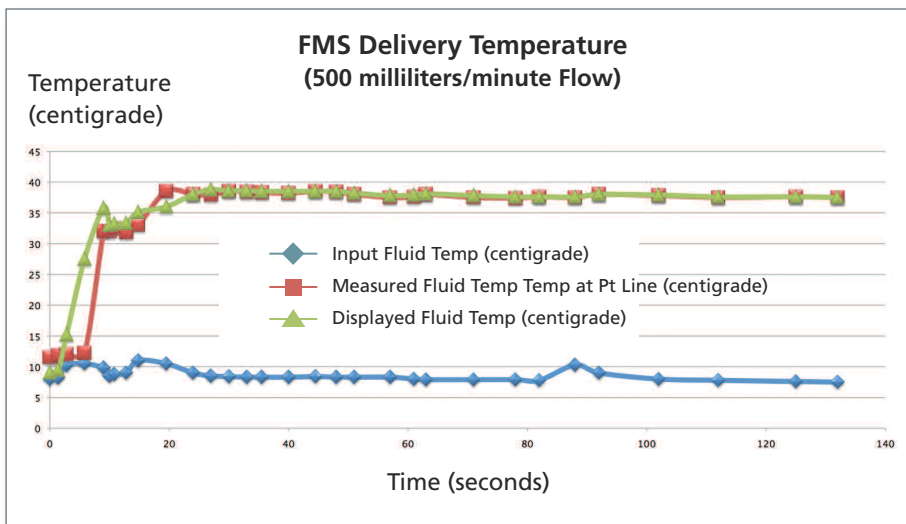

→ Two Disposable Options

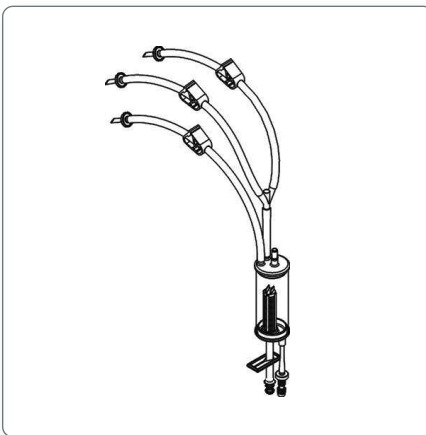

120 ml Reservoir

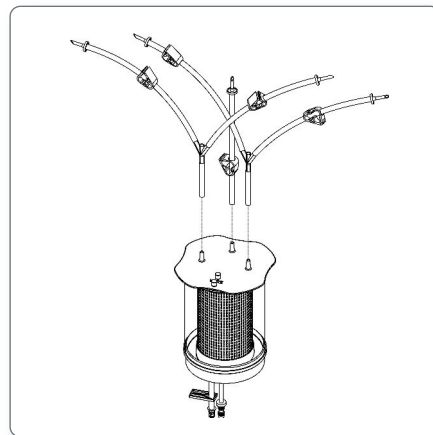

Optional 3.0 Liter Reservoir

Easy to Use

Graphical display and simplified touch screen make the system easy to use even when something goes wrong.

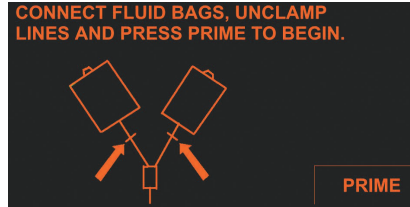

Prime Screen



Infuse Screen

Safety Simplified

The Belmont Rapid Infuser automatically and continuously monitors both the infusion process and the device operation. If an unsafe condition occurs, alarms identify the problem and the touch screen displays how to solve it.

At each alarm condition, the system stops pumping and heating, and closes off the patient line. Instantly, fluid to the patient is rerouted back to the reservoir.

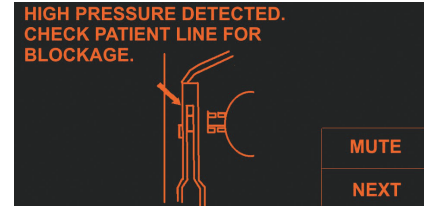

High Line Pressure Alarm Screen

The Belmont® Rapid Infuser

Ordering Information:

Rapid Infuser, 1000 ml/min:	Infusion rate: 2.5-1000 ml/min
	US: part # 903-00023 (120V)
	International: part # 903-00024 (230V)
Rapid Infuser, FMS 2000:	Infusion rate: 2.5-750 ml/min
	US: part # 903-00001 (120V)
	International: part # 903-00001A (230V)
	Military Field Model: part # 903-00001B
	NSN 6515014652059
Standard Disposable:	part # 903-00006
Special 3 Liter Reservoir:	part # 903-00018

Hardware Specifications:

Dimensions:	13.5 in. x 7.5 in x 12 in.
Weight:	28 lbs.
Portability:	Quick-on IV pole mount or handle at top of unit.
Power:	115 volt or 220/240 volt AC input.
Battery:	Internal, rechargeable for transport. Operates all functions without heating.
Fluid Pump:	Roller type peristaltic pump. Flow rate 2.5-1000 ml/min.
Heater:	Maximum applied power, 1440 watts.
Sensors:	2 air bubble sensors, pressure transducer (fluid), 2 temperature probes (infrared sensing), pump flow rate sensor, open door detector, and valve activation sensor.
Control Computer:	Built-in, controls all functions, with redundant hardwired override protection in case of computer failure.
Display:	5 in. x 2.5 in. electroluminescent type with waterproof touch pad.



Made in the U.S.A. The Belmont® Rapid Infuser has been evaluated with respect to electrical safety, fire and mechanical hazards, in accordance with UL2601-1, CAN/CSA C22.2 No. 601.1-M90, and EN 60601-1: 1990 + A1: 1993 + A11 1993 +A12: 1993 + A2: 1995 + A13: 1996; Electromagnetic Compatibility [EN60601-1-2 (2001) and IEC60601-1-2 (2001)] and Programmable Electronic Compatibility system [IEC60601-1-4]

The Belmont® is the property of Belmont Instrument Corporation © 2009 12179-1209.



Belmont Instrument Corporation
780 Boston Road
Billerica, MA 01821 USA
T: 866-663-0212
F: 978-663-0214
www.belmontinstrument.com