

# Model S-265 Scoop Users' Manual



## Specifications:

**Length: open ... 166 cm (minimum)**

**Length: folded ... 120 cm**

**Width ... 42.2 cm**

**Height: open ... 6.7 cm**

**Height: folded ... 10 cm**

**Weight ... 9.75 kg**

**Load Capacity ... 159 kg**

The **Model S-265 Scoop Stretcher** (stretcher) is an emergency patient-handling device. It is designed to aid in moving a patient when space is limited or when the patient needs to be moved with little change of body position. Operate the stretcher according to the laws and protocols of the country where it is used. Consult the appropriate authorities for information regarding laws and protocols, and resolve any questions before using the stretcher with a patient.

The stretcher is for professional use by a minimum of two trained operators.

The stretcher frame is constructed in two halves which uncouple, slide under the patient, then recouple for lifting the patient. The stretcher may also be used in a "V" shape when uncoupled at only the foot end.

Other features include a telescoping foot section with locking positions for length adjustment, three handholds on each side of the main frame, and concealed hinges which allow the stretcher to fold for storage.

The Model S-265 stretcher is equipped with a set of three patient restraints.

## A. Stretcher Components

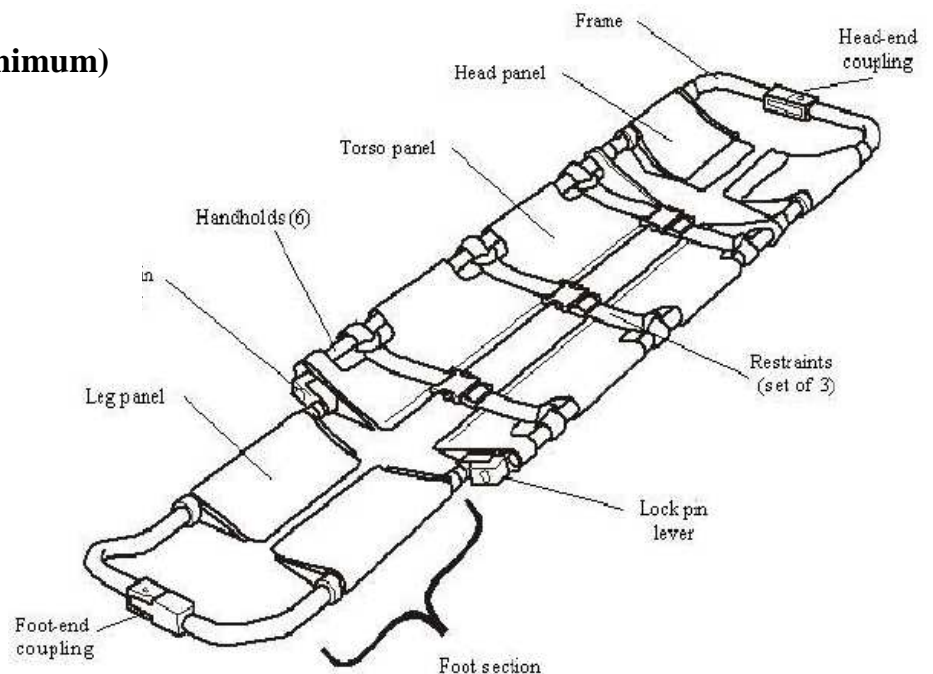

Manufacturer & Authorised EU Representative –  
Saver Manufacturing, s.r.o. ( A FERNO Group Company)  
Bosaca 893  
913 07 Bosaca  
Slovakia  
Tel: +421 32 7781159



Distributed by –  
Ferno (UK) Ltd.  
Ferno House  
Stubs Beck Lane  
Clackheaton  
West Yorkshire BD194TZ UK  
Tel: +44 (0)1274 851999

## B. Adjusting Stretcher Length

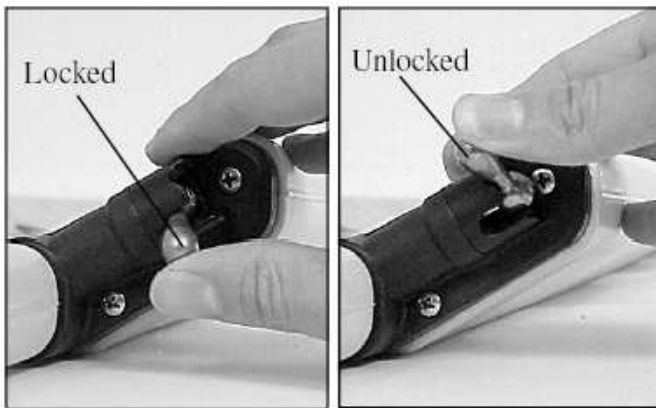

**Figure 1: Using the Lock-Pin Lever**

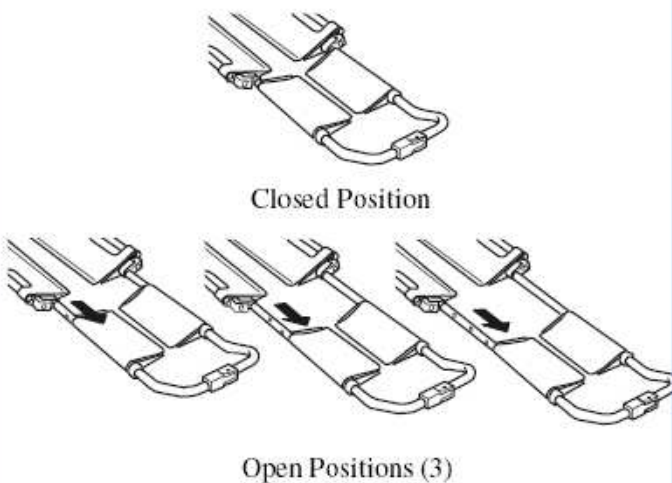

**Figure 2: Foot Section Positions**

Adjust the length of the stretcher to the patient's height **before** uncoupling the halves. This ensures equal adjustment to both halves.

### TO LENGTHEN OR SHORTEN THE STRETCHER

1. Move the lock-pin lever on each side of the frame to the unlocked position (Figure 1).

**Note:** When the stretcher is lying face-up on a flat surface, the locked position is "down" and the unlocked position is "up" (Figure 1).

2. Pull the foot section outward to the desired length, stopping near one of the locking positions located at the holes along the foot-section frame.
3. Return both lock-pin levers to the locked position (Figure 1).
4. Push or pull the foot section a little until it locks into place.
5. Make sure both sides are securely locked.

## C. Applying the Stretcher

### Figure 3: Uncoupling the Joined Ends

To separate the stretcher halves, use thumbs to press the Twin Safety Lock levers on each end coupling and pull the coupling halves away from each other.



**Figure 3 - Joined End Coupling**

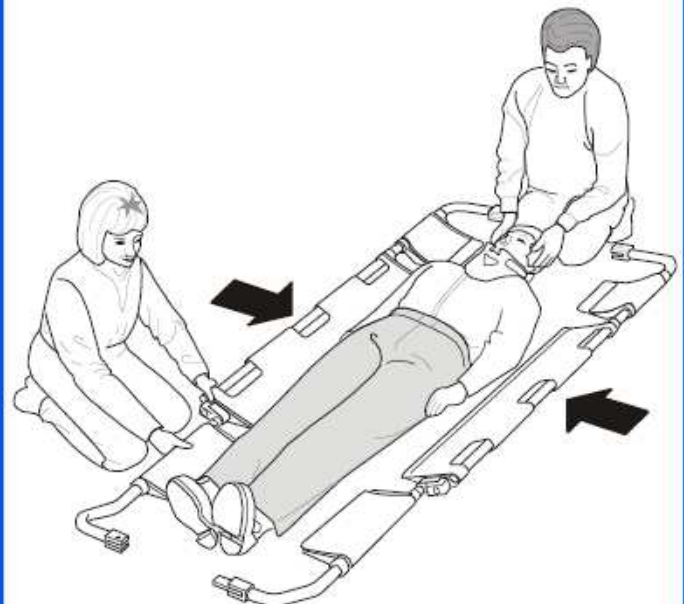

**Figure 4 - Applying the Stretcher Halves**

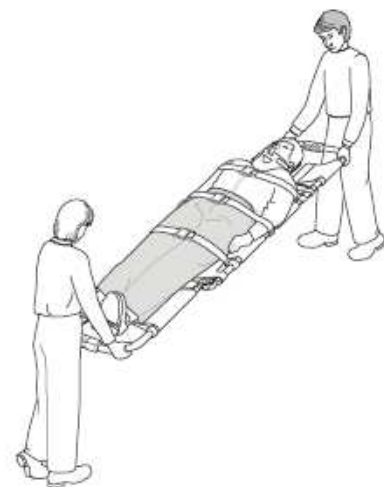

**Figure 5 - Carrying the Stretcher**

## D. Applying the Stretcher in a “V”

Unfold the stretcher if it is folded for storage, and adjust the length (see B. Adjusting Stretcher Length).

1. Unfasten the restraints (if stored on stretcher).
2. Open only the foot-end coupling.
3. Pull the foot end halves of the stretcher apart to form a “V” shape.
4. Position the stretcher with the patient’s head at the base of the “V” (Figure 6).

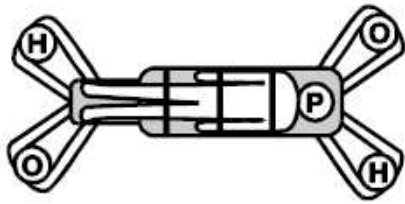
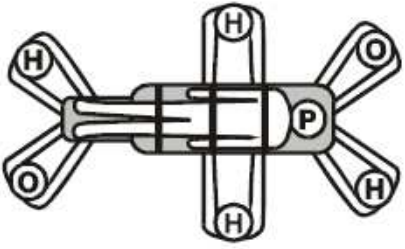

**Figure 6 - Applying Stretcher in “V” shape**

5. Use locally-approved EMS procedures to work the stretcher inward and under the patient. Work from head to foot until the coupling halves at the foot end meet.

To avoid pinching or pulling the patient’s skin, hair, or clothing, use care while working the stretcher halves into place beneath the patient.

## E. Using Additional Help

Helpers	Lifting and Carrying
Two Operators + Two Helpers	
Two Operators + Four Helpers	

**Key:**

*O = Operator H = Helper P = Patient*

## F. Storing the Stretcher

To fold the stretcher for storage:

1. Unlock the lock-pin levers on both sides of the stretcher.
2. Fully extend the foot section by pulling it out until the hinges are completely visible.
3. Lift the foot section and fold it over onto the torso panel (Figure 7).

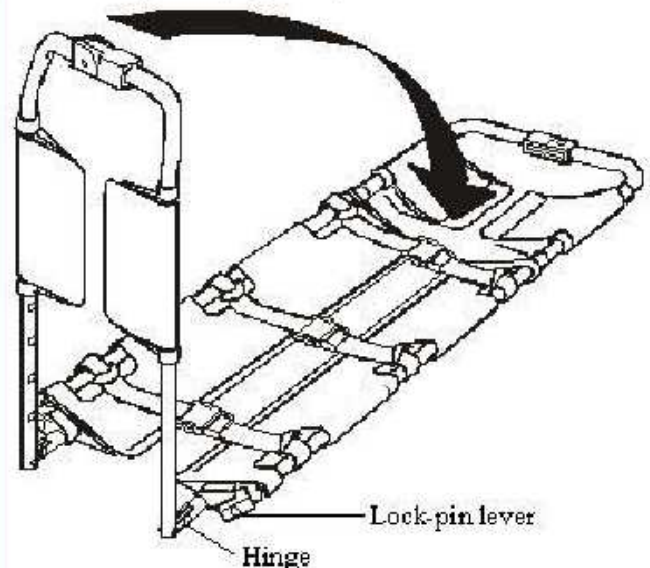

**Figure 7 - Folding the Stretcher**

## G. Attaching Restraints

The Model S-265 Scoop Stretcher includes a set of three two-piece restraints.

To attach a two-piece restraint:

1. Unbuckle the restraint, separating it into two pieces.
2. Pass the looped end of one restraint piece upward through a handhold opening on stretcher frame.
3. Hold the loop open and thread the buckle of restraint through loop (Figure 8).
4. Pull the webbing through the loop until the loop is snug against stretcher frame.

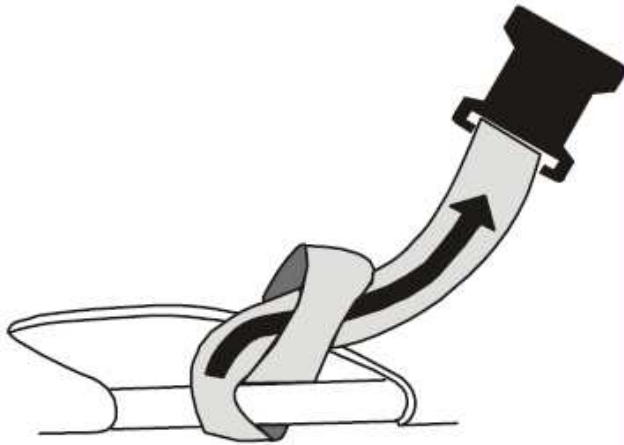

**Figure 8 - Attaching Two-Piece Restraint**

5. Repeat steps 2-4 to attach the other half of the restraint to opposite handhold.
6. Attach the remaining two restraints following steps 1-5.
7. Confirm that all restraints are securely fastened.

## H. Lubricating the Stretcher

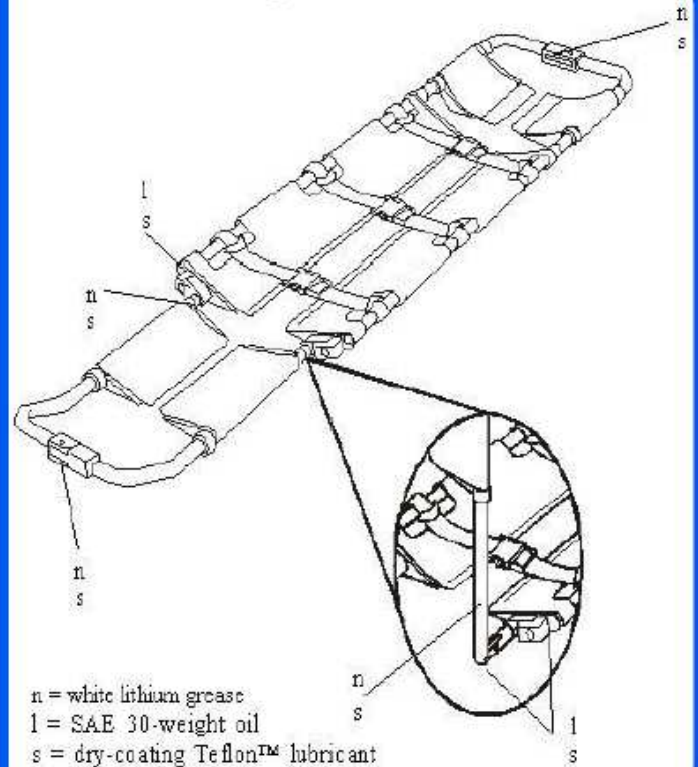

n = white lithium grease  
l = SAE 30-weight oil  
s = dry-coating Teflon™ lubricant

*Note: Use "l" + "n", or "s" for lubricating marked points*

## **⚠ WARNING**

**Improper use of the stretcher can cause injury. Use the stretcher only for the purpose described in this manual.**

**Untrained operators can cause injury or be injured. Permit only trained personnel to operate the stretcher.**

**Improper operation can cause injury. Operate the stretcher only as shown in this manual.**

**An unattended patient can be injured. Stay with the patient at all times.**

**An unrestrained patient can fall off the stretcher and be injured. Use restraints to secure the patient in the stretcher.**

**Untrained helpers can cause injury or be injured. Operate and maintain control of the stretcher and direct any helpers.**